

U-BAR DETAIL

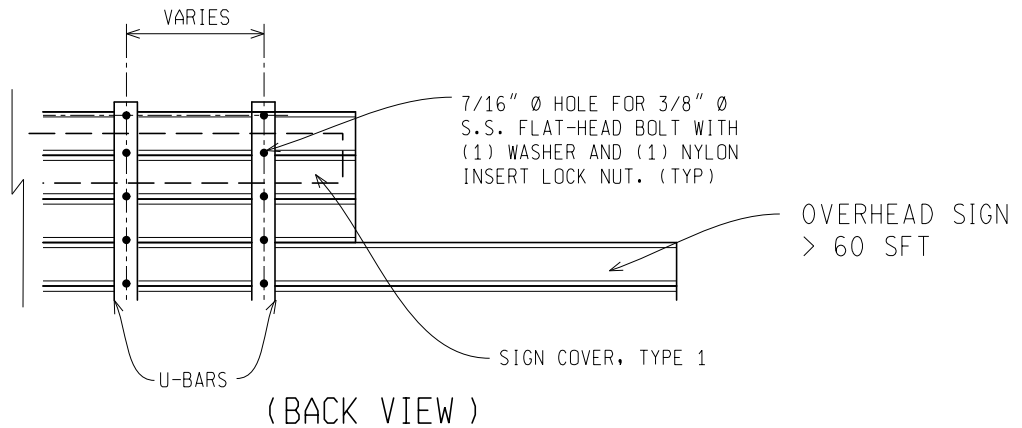

NOTES:

1. ALL CONNECTIONS ARE INCIDENTAL TO PAY ITEM "SIGN COVER, TYPE 1".
2. ALL STEEL PARTS SHALL CONFORM TO MDOT STANDARD SPECIFICATIONS FOR CONSTRUCTION. MATERIALS SHALL CONFORM TO AASHTO M270, GRADE 36. UNLESS OTHERWISE INDICATED, GRADE 50 OR 50W MATERIAL BE SUBSTITUTED FOR GRADE 36 MATERIAL.
3. ALL STRUCTURAL STEEL TO BE HOT DIP GALVANIZED AFTER FABRICATION PER ASTM A123.
4. U-BAR SUPPORT SUITABLE FOR PLYWOOD AND ALUMINUM SUBSTRATES.
5. ATTACH U-BAR SUPPORT UTILIZING C-CHANNELS ON THE BACK OF ALUMINUM EXTRUSION SUBSTRATES OR IN A MANNER APPROVED BY ENGINEER.

NTS

SIGN COVER, TYPE 1